

Grandview

Electrical Chain-Type Constant Speed Commercial Hoist Instruction Manual

Model:GCRT-10012

Grandview

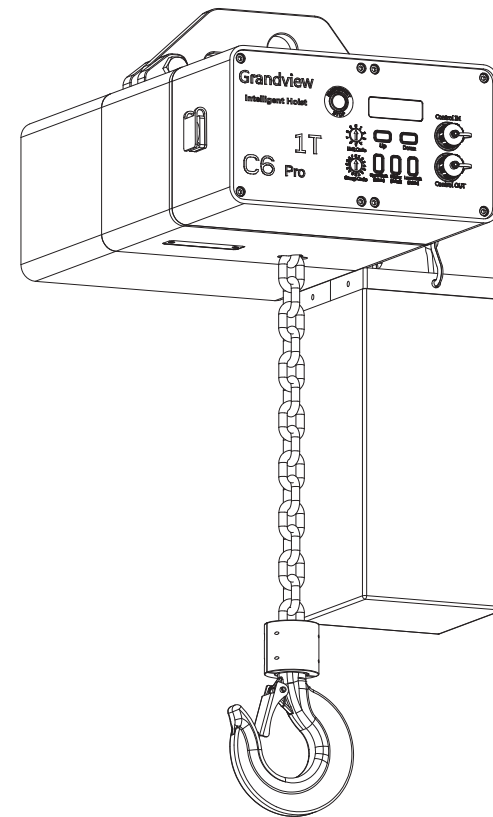

Guangzhou Grandview Creative Technology Co., Ltd

Add: No.1 Building of No.43 South International Trade Avenue,

Hualong Town, Panyu District, Guangzhou China.

Tel: +8620-8489-9499 Fax: +8620-8480-5299

Http://www.grandviewscreen.com



Troubleshooting Detection

Code and meaning value	
Code	Meaning Value
5 6 9 7	Upper limit setting
5 6 9 8	Lower limit setting
6 9 9 9	Strap loosen
6 6 6 6	Host setting
Troubleshooting detection	
Defects	Solution
Temporarily stop and tip during multiplelifter applied	Reset
Temporarily stop during lifting, 485 transmitting interference	Restart power
Starting with delay or stop	Send 2 code in the same time
System error	Restart power
Hoist could not be lowered; abnormal sound	Might be the mis-trigger of anti-dropping device, pressstop and up to see if the hoist recover
Hoist retract with chain stuck	Check if there is damage at the lining holeand polish it with file gently
During the downward running of the equipment, if you find the stop situation	Please check whether the chain is knotted. If so, please straighten outthe chain.

Bit code			Code value
The first one	Second	The third	Hexadecimal
OFF	OFF	OFF	00
OFF	OFF	ON	01
OFF	ON	OFF	02
OFF	ON	ON	03
ON	OFF	OFF	04
ON	OFF	ON	05
ON	ON	OFF	06
ON	ON	ON	07

Example

Example

Bit code	Group code	0000	0001	0010
000	UP	F6 00 00 07 FD	F6 01 00 07 FE	
	STOP	F6 00 00 09 FF	F6 01 00 09 00	
	DOWN	F6 00 00 08 FE	F6 01 00 08 FF	
001	UP	F6 00 01 07 FE	F6 01 01 07 FF	
	STOP	F6 00 01 09 00	F6 01 01 09 01	
	DOWN	F6 00 01 08 FF	F6 01 01 08 00	
010	UP	F6 00 02 07 FF	F6 01 02 07 00	
	STOP	F6 00 02 09 01	F6 01 02 09 02	
	DOWN	F6 00 02 08 00	F6 01 02 08 01	
011	UP	F6 00 03 07 00	F6 01 03 07 01	
	STOP	F6 00 03 09 02	F6 01 03 09 03	
	DOWN	F6 00 03 08 01	F6 01 03 08 02	

If the user still does not know the dialing method, you can download the encoding software on the official website or contact the sales agent to obtain the encoding software.

Multiple Device Wiring

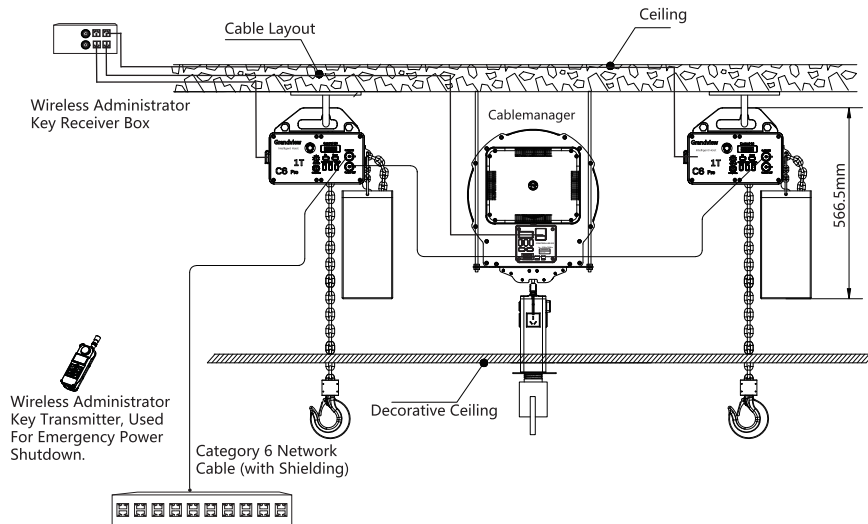

Connect to Central Control or Wall-Mounted Control Switch.

When multiple devices are used together, they can be connected to the matching receiver and used with the wireless administrator key. As shown in the figure, the first device is connected to the receiver, and the other part of the receiver is connected to the central control host. The other devices can be connected to each other; all device power cables must also be powered from the receiver. (Internal wiring is only for supplying current to three hoisting points and one retraction device.)

Precautions

- The installation position should have sufficient mechanical strength. The load-bearing requirement is 4 times the weight of the lifting point and the weight of the stage equipment to prevent the equipment from falling off.
- When installing the device, make sure that each screw is tightened to prevent the device from loosening and affecting the safety of use.
- Please pay attention to the protection and maintenance of the lifting points, check regularly:
 - If there are stains, please wipe with a soft cloth
 - When removing dust, wipe it gently with a soft brush
 - Regularly check the screws for signs of looseness
 - Chains are worn out goods. Need regular and appropriate maintenance with anti-rust oil
- In order to avoid unnecessary injury, it is recommended that the management and installation of the equipment be operated and maintained by professionals.
- Do not pull the device by hand during use to avoid damage to the device.
- Do not install the product in a location that is wet or likely to splash.
- Only connect the power plug with the grounding wire. If the accessory is damaged, please contact the supplier or the after-sales personnel.
- Please use the approved power cord (3-core power cord) / device interface / plug, the grounding plug should be in compliance with the applicable safety regulations of the country.
- When installing the rigging point, configure an easy-to-use power-off device in the fixed wiring, or connect the power plug to an electrical outlet that must be close to the device and easy to use. If a malfunction occurs while operating the device, you can turn off the power to the power-off device to disconnect the device or disconnect the power plug.
- Keep away from heat or moisture.
- As long as the plug of the rigging point is also connected to the power supply, the unit is not disconnected from the AC power supply.
- Unplug the power cord when you are experiencing lightning or thunderstorms or when not in use for a long time.

It is forbidden to stand under the equipment during the lifting process, beware of accidents.

If the screw is found to be loose, please contact the after-sales personnel or the user to replace the screw. If the user ignores the warning, the user should solve the problem.

This instruction manual is subject to change without prior notice. Please contact your sales representative.

	The user must periodically check if the device screws are loose.		When using, you must have professional personnel to operate on site. Beware of emergency stoppage when equipment is faulty.
	After the rigging point is completely lowered, the bottom of the rigging point should be no less than 1.8 meters from the ground to prevent children from touching.		Do not disassemble the rigging points or loosen the rigging point screws. If repairing or correcting, please contact our company or sales agent.
	When two devices or more are used at the same time, the sum of the weights of the two devices must not exceed		

Note: Users are not allowed to disassemble and replace parts at will. If there is any fault, Must contact the after-sales service department for repair; the functional structure is subject to change without prior notice. Subject to the product!

Diagram

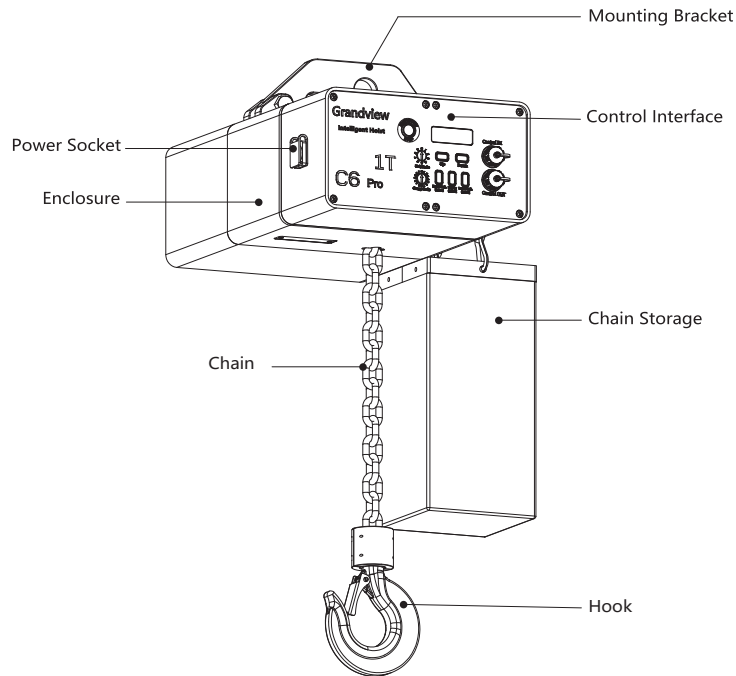

Standard Accessories

- Nine Pin Socket x2
- Cable x1
- Chain Recovery Bag x1
- Qualified Certificate x1
- Manual x1
- Limit Adjustment Tool x1

Optional Accessories

- Wall Switch



Group Code & Bit Code

When connect via RS485, Group code and bit code must be nonzero.

Group code range(1-15); Bit code range(1-9).

When the other equipment connect to same hoist, make it into same Group, but must have a different Bit Code.

When the other equipment install in the same room, please try to make it into same Group

Rs485 Protocol

Serial Port—Baud Rate(9600),8 Bits Data, 1 Stop,Cyclic Redundancy Check(CRC).

Protocol Format: Hexadecimal

Packet Header(F6),Group Code, Bit Code, Command Code, Parity Checking(Single Byte)

Parity Checking=Packet Header + Group Code +Bit Code + Command Code Cyclic Redundancy Check(CRC)

Coding= Generator Polynomial-1

Common Command Code	07	Hoist Up
	08	Hoist Down
	09	Hoist Stop

RS-485 Group Code(Dial Code Setup)

Group Code				Dial Code
1ST Group	2nd Group	3rd Group	4th Group	Hexadecimal
OFF	OFF	OFF	OFF	00
OFF	OFF	OFF	ON	01
OFF	OFF	ON	OFF	02
OFF	OFF	ON	ON	03
OFF	ON	OFF	OFF	04
OFF	ON	OFF	ON	05
OFF	ON	ON	OFF	06
OFF	ON	ON	ON	07
ON	OFF	OFF	OFF	08
ON	OFF	OFF	ON	09
ON	OFF	ON	OFF	0a
ON	OFF	ON	ON	0b
ON	ON	OFF	OFF	0c
ON	ON	OFF	ON	0d
ON	ON	ON	OFF	0e
ON	ON	ON	ON	0f

When Group code and bit code done, please setup command code with above encode table. Baud rate(9600),Hexadecimal dial code.

Key Group Control Code(0000 000), so the Rigging Hoist Group Code and Bit code must be out of this range.

Control Interface

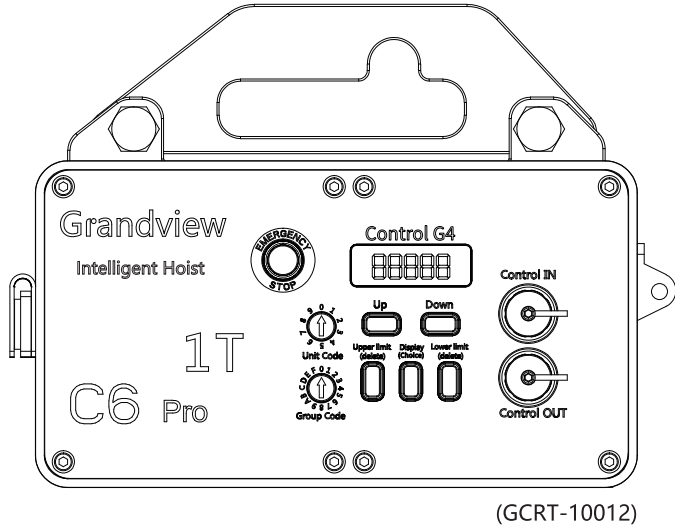

Emergency Stop Button
 Button down - the equipment is in debugging and normal use
 Button Release - the device is in a prohibited state



Up, Down
 Long Press



Bit Code Button



Group Code Button



Upper Limit Setting Button:
 Long press 3 second, you will hear 3 ticking from the hoist, then start setup upper limit. Press up and down button to setup the height you want. When in the height of target, press 4 -5 second you will hear 4 ticking from the hoist, then upper limit done.



Reset Button
 Long press to reset.
 Press in turn(Display Distance, Speed, Current Values, Frequency)



Lower Limit Setting Button:
 Long press 3 second, you will hear 3 ticking from the hoist, then start setup lower limit. Press up and down button to setup the height you want. When in the height of target, press 4 -5 second, you will hear 4 ticking from the hoist, then lower limit done.

Control IN



- 1-3B(CAN)
- 2-5A(CAN)
- 3-NC
- 4-NC
- 5-3B(485)
- 6-5A(485)
- 7-GND
- 8-UP
- 9-DOWN

Parallel Connection



Control OUT

port 6: Positive
 port 5: Negative

Specification

GCRT-10012

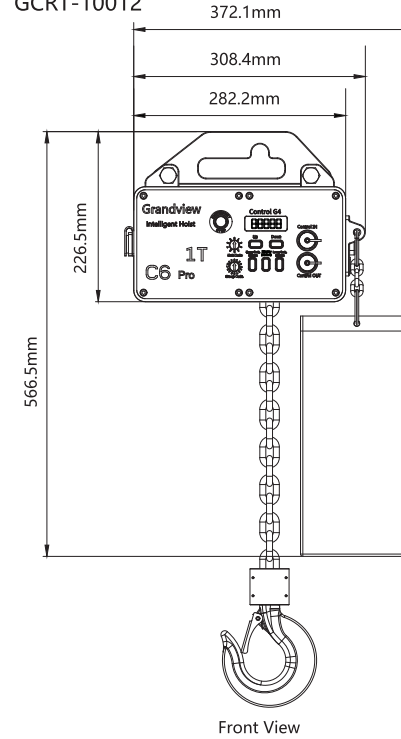

Front View

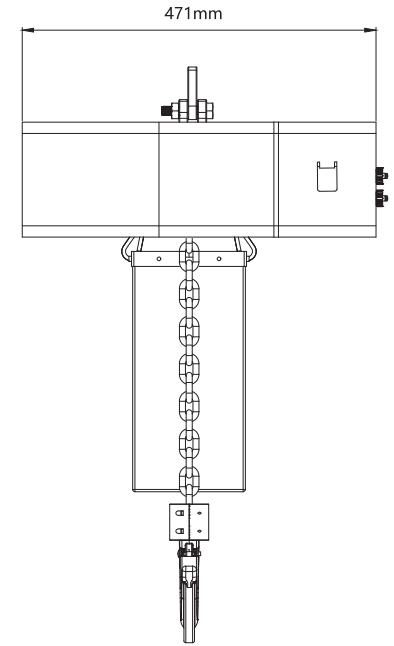

Side View

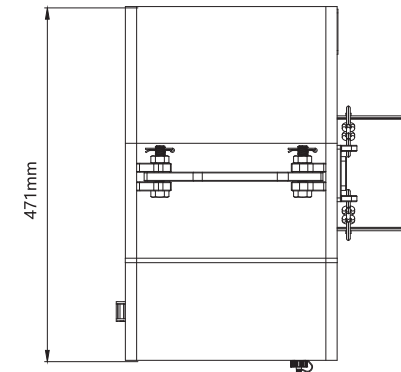

Top View

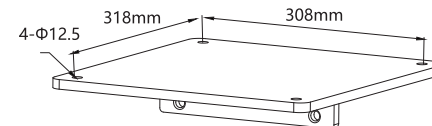

Installation Board
 (Optional Accessory)

GCRT-10012

**Item: Commercial Rigging System
 (Constant Speed Control)**

Code:GCRT-10012

Size:W471xD282.2x566.5mm

Installation Method: Can be mounted upright (or inverted), depending on requirements.

Ceiling Open Size:φ205mm

Loading Capacity:1000kg

Max Dropping Distance:12 Meter

Input Voltage:AC 220v 50Hz

Power Rating:1000W

Lifting Speed:4.2m/min

Control: RS-485/Dry Contact/Wall Switch

Load Chain Grade: G80

Installation Instruction

This product should be installed in the best projection position, it would be more convenient and more safe when the product being installed correctly, firstly, open the package and check if there is any missing parts, then take out all the parts and start the installation as per the instructions below, to make sure the product operates more safe and more convenient, pls read through the whole instruction carefully and choose the appropriate installation way based on the actual installation environment;(Can be mounted upright or inverted)

*Power for hoist is 1000W, for cable manager is 60W, pls notice this when connecting the cables.

*Installation can be arranged in the end of decoration, the decorative light circle of the bag can well cover the hole of smallpox, keep the appearance clean, and do not need a second decoration after installation.

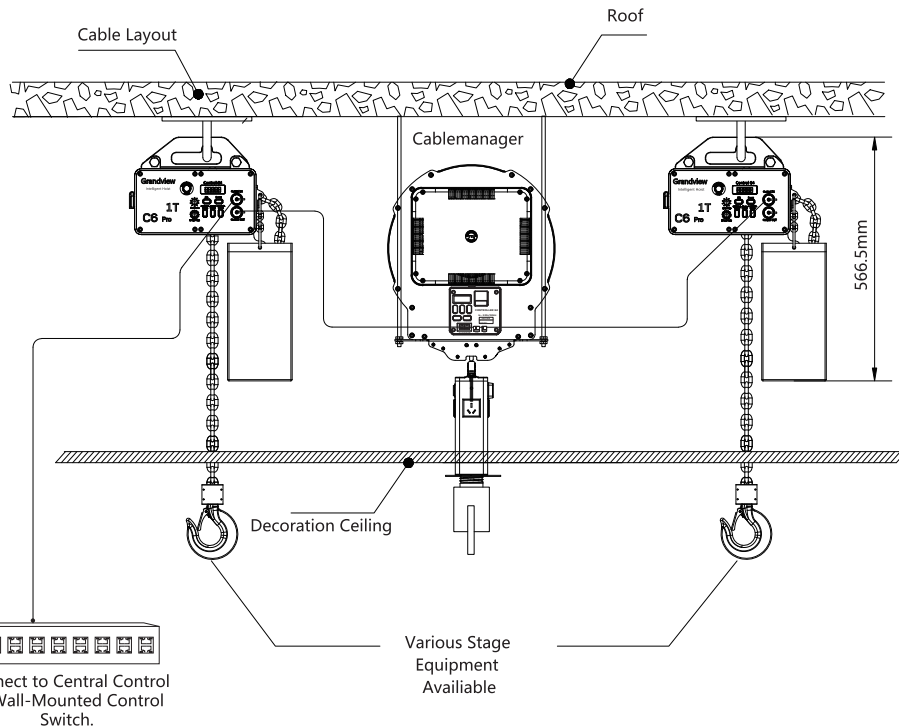

(Ceiling-concealed electric hoist series installation diagram. Please note that the wire retraction device is not a load-bearing product.)

Notice:

- 1、 End user can choose any port to connect the wall switch or central control;
- 2、 Hangers must keep straight;
- 3、 When returning the chain, please make sure all the stage equipments have been disassembled to avoid it hit the ceiling;

Installation Guidelines

1. Hoisting Point Hook Installation:

The system supports both upright and inverted installations.

The installation method can be selected based on the customer's site conditions for optimal flexibility and convenience.

2. Versatile Installation Applications:

This hoisting system is suitable for both permanent indoor installations and mobile outdoor setups, including large-scale concerts and events.

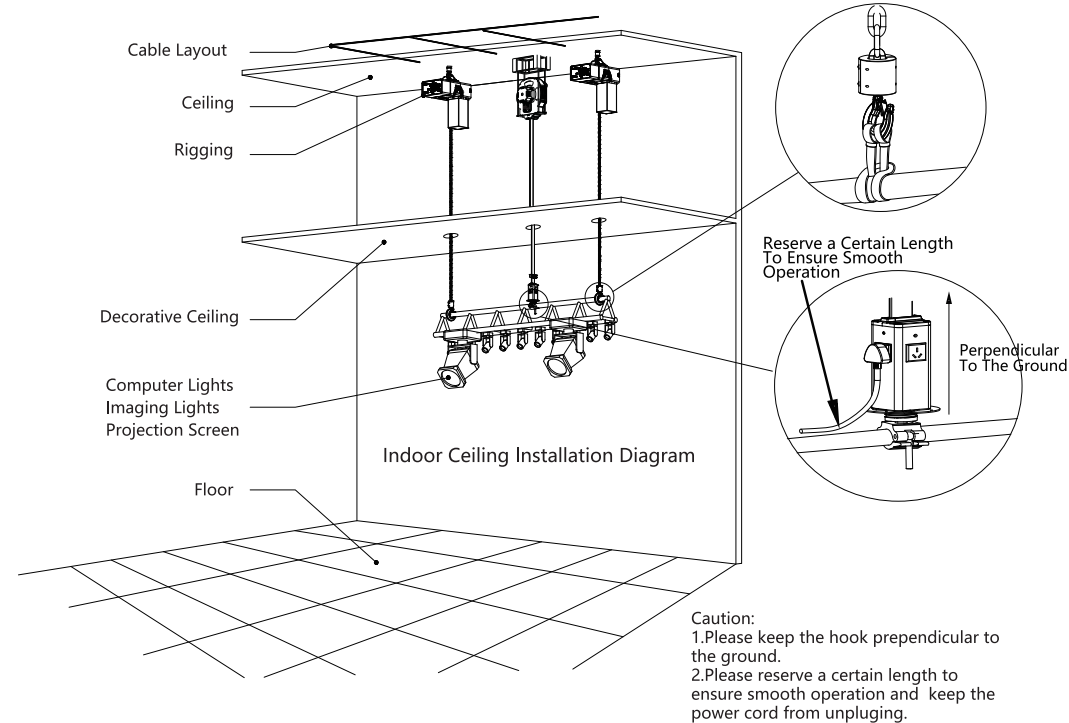

Mechanical Limit Adjustment

Chain Hoist Height Adjustment (Upper and Lower Mechanical Limits):

Mechanical Lower Limit:

- Turn the adjustment knob clockwise to raise the chain (shorten the chain).
- Turn the adjustment knob counterclockwise to lower the chain (lengthen the chain).

Mechanical Upper Limit:

- Turn the adjustment knob clockwise to raise the chain (shorten the chain).
- Turn the adjustment knob counterclockwise to lower the chain (lengthen the chain).

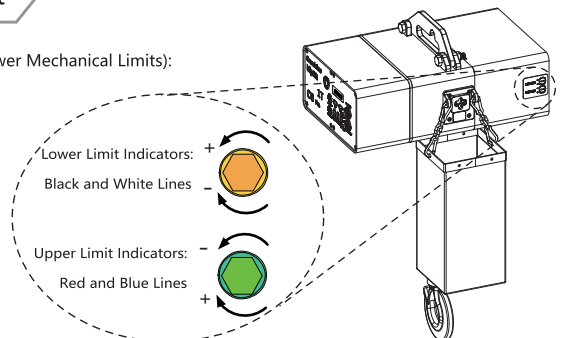

Note: Mechanical limit adjustments should only be carried out by qualified personnel or by contacting the sales technician for assistance.