

Grandview

Electric Chain Hoist with Numerical Control User Manual

Model: GCRT-2512

Grandview

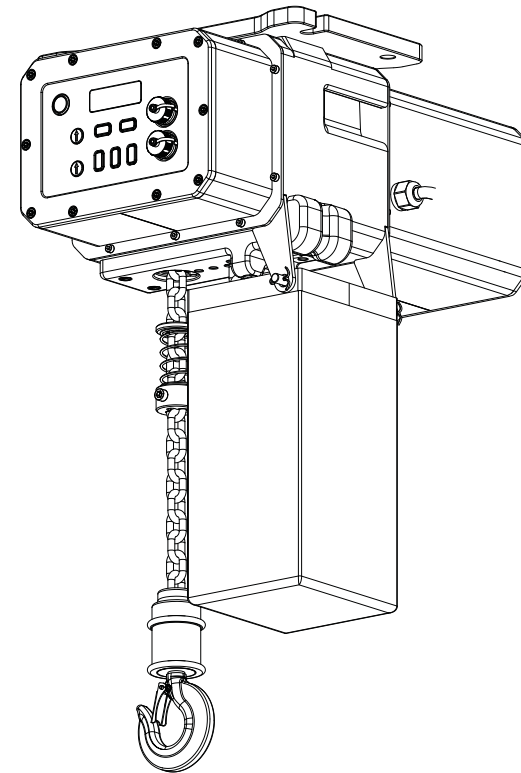

Guangzhou Grandview Creative Technology Co., Ltd

Add: No.1 Building of No.43 South International Trade Avenue,
Hualong Town, Panyu District, Guangzhou China.

Tel: +8620-8489-9499 Fax: +8620-8480-5299

Http://www.grandviewscreen.com



Thank you for purchasing this product. Please read instructions carefully before using. After installation, store instructions for future reference.

Troubleshooting detection

Code and meaning value	
Code	Meaning Value
5 6 9 7	Upper Limit Setting
5 6 9 8	Lower Limit Setting
6 9 9 9	Strap Loosen
6 6 6 6	Host Setting
Troubleshooting detection	
Defects	Solution
Temporarily stop and tip during multiple lifter applied	Reset
Temporarily stop during lifting, 485 transmitting interference	Restart power
Starting with delay or stop	Send 2 code in the same time
System Error	Restart power
Rigging system could not be lowered; abnormal sound	Might be the mis-trigger of anti-dropping device, press stop and up to see if the rigging system recover
Rigging system retract with chain stuck	Check if there is damage at the lining hole and polish it with file gently
During the downward running of the equipment, if you find the stop situation	please check whether the chain is knotted. If so, please straighten out the chain.

Multiple device wiring

Multiple rigging points combined emergency braking and multiple control diagram.

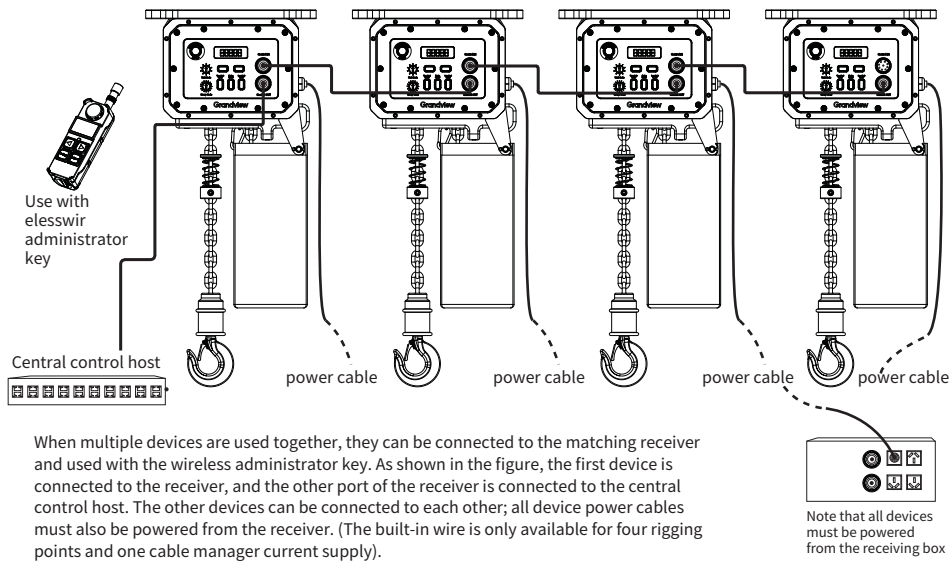





When multiple devices are used together, they can be connected to the matching receiver and used with the wireless administrator key. As shown in the figure, the first device is connected to the receiver, and the other part of the receiver is connected to the central control host. The other devices can be connected to each other; all device power cables must also be powered from the receiver. (The built-in wire is only available for four rigging points and one cable manager current supply).

Precautions

- The installation position should have sufficient mechanical strength. The load-bearing requirement is 4 times the weight of the lifting point and the weight of the stage equipment to prevent the equipment from falling off.
- When installing the device, make sure that each screw is tightened to prevent the device from loosening and affecting the safety of use.
- Please pay attention to the protection and maintenance of the lifting points, check regularly:
 - If there are stains, please wipe with a soft cloth.
 - When removing dust, wipe it gently with a soft brush.
 - Regularly check the screws for signs of looseness.
 - Chains are worn out goods need regular and appropriate maintenance with anti-rust oil.
- In order to avoid unnecessary injury, it is recommended that the management and installation of the equipment be operated and maintained by professionals.
- Do not pull the device by hand during use to avoid damage to the device.
- Do not install the product in a location that is wet or likely to splash.
- Only connect the power plug with the grounding wire. If the accessory is damaged, please contact the supplier or the after-sales personnel.
- Please use the approved power cord (3-core power cord) / device interface / plug, the grounding plug should be it complies with the applicable safety regulations of the country.
- When installing the rigging point, configure an easy-to-use power-off device in the fixed wiring, or connect the power plug to an electrical outlet that must be close to the device and easy to use. If a malfunction occurs while operating the device, you can turn off the power to the power-off device to disconnect the device or disconnect the power plug.
- Keep away from heat or moisture.
- As long as the plug of the rigging point is also connected to the power supply, the unit is not disconnected from the AC power supply.
- Unplug the power cord when you are experiencing lightning or thunderstorms or when not in use for a long time.

It is forbidden to stand under the equipment during the lifting process, beware of accidents. If the screw is found to be loose, please contact the after-sales personnel or the user to replace the screw. If the user ignores the warning, the user should solve the problem. This instruction manual is subject to change without prior notice. Please contact your sales representative.

 <p>Caution</p>	<p>The user must periodically check if the device screws are loose.</p>	 <p>Force</p>	<p>When using, you must have professional personnel to operate on site. Beware of emergency stoppage when equipment is faulty.</p>
 <p>Pay attention to children's touch</p>	<p>After the rigging point is completely lowered, the bottom of the rigging point should be no less than 1.8 meters from the ground to prevent children from touching.</p>	 <p>Disassemble Prohibited</p>	<p>Do not disassemble the rigging points or loosen the rigging point screws. If repairing or correcting, please contact our company or sales agent.</p>
 <p>Warning</p>	<p>When two devices or more are used at the same time, the sum of the weights of the two devices must not exceed</p>		

Note: Users are not allowed to disassemble and replace parts at will. If there is any fault, Must contact the after-sales service department for repair; the functional structure is subject to change without prior notice. Subject to the product!

Diagram

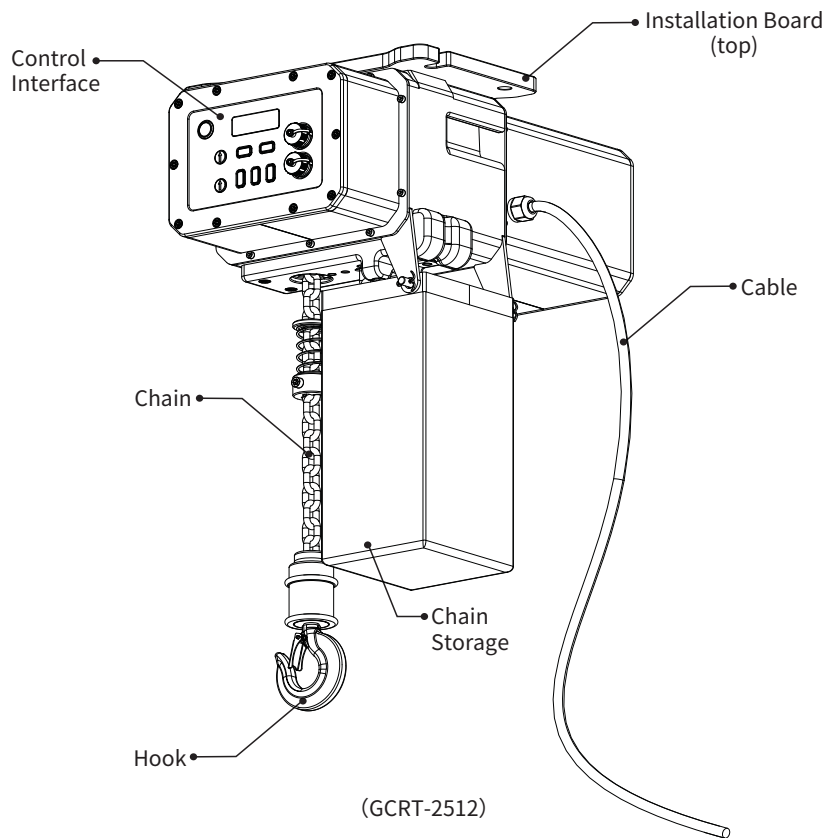

Standard Accessories

- 6 Inches Cushion x1
- nine pin Socket x2
- Chain(with Mounting Rod) x1
- Chain recovery bag x1
- Qualified Certificate x1
- Cotter pin x2
- Manual x1



Optional Accessories

- Wall Switch
- Wireless Administrator Controller
- Receiver (Match with Wireless Administrator Controller)

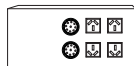

Group Code & Bit Code

Group code and bit code settings:

When using RS485, the group code and bit code are non-zero numbers. For example, 01 01 is the first device of the first group, and 01 02 is the second device of the first group. Among them, the group control group code and bit code are 00 00

RS485 protocol

Serial port settings:

Baud rate: 9600

Data bits: 8 bits

Stop bit: 1 bit

Correction: CRC

Script	07	UP
	08	DOWN
	09	STOP
	A6	Code learning

Protocol format (hexadecimal)

Packet header (F6), group code, bit code, instruction code, CRC

CRC = packet header + group code + bit code + instruction code CRC correction digits = generator polynomial digits -1

Group control code

UP F6 00 00 07 FD DOWN F6 00 00 08 FE

STOP F6 00 00 09 FF

When setting the code, learn the code first. For example, learn the first device of the first group: F6 01 01 A6 9E, where 9E=F6+01+01+A6 (calculated by a hexadecimal calculator), then the group code is 01, bit Code bit 01, the control code is calculated with a hexadecimal counter

UP: F6 01 01 07 FF DOWN: F6 01 01 08 00 Stop: F6 01 01 09 01, other codes are calculated in the same way

Group code、 bit code list:

Group code	Bit code	Up control code	Down control code	Stop control code
00 (Group control)	00 (Group control)	F6 00 00 07 FD	F6 00 00 08 FE	F6 00 00 09 FF
01 (First group)	00 (First control group)	F6 01 00 07 FE	F6 01 00 08 FF	F6 01 00 09 00
	01 (Unit 1 of the first group)	F6 01 01 07 FF	F6 01 01 08 00	F6 01 01 09 01
	02 (Unit 2 of the first group)	F6 01 02 07 00	F6 01 02 08 01	F6 01 02 09 02
	03 (Unit 3 of the first group)	F6 01 03 07 01	F6 01 03 08 02	F6 01 03 09 03
02 (Second group)	04 (Unit 4 of the first group)	F6 01 04 07 02	F6 01 04 08 03	F6 01 04 09 04
	00 (Second control group)	F6 02 00 07 FF	F6 02 00 08 00	F6 02 00 09 01
	01 (Unit 1 of the second group)	F6 02 01 07 00	F6 02 01 08 01	F6 02 01 09 02
	02 (Unit 2 of the second group)	F6 02 02 07 01	F6 02 02 08 02	F6 02 02 09 03
03 (Third group)	03 (Unit 3 of the second group)	F6 02 03 07 02	F6 02 03 08 03	F6 02 03 09 04
	04 (Unit 4 of the second group)	F6 02 04 07 03	F6 02 04 08 04	F6 02 04 09 05
	00 (Third control group)	F6 03 00 07 00	F6 03 00 08 01	F6 03 00 09 02
	01 (Unit 1 of the third group)	F6 03 01 07 01	F6 03 01 08 02	F6 03 01 09 03
.....	02 (Unit 2 of the third group)	F6 03 02 07 02	F6 03 02 08 03	F6 03 02 09 04
	03 (Unit 3 of the third group)	F6 03 03 07 03	F6 03 03 08 04	F6 03 03 09 05
	04 (Unit 4 of the third group)	F6 03 04 07 04	F6 03 04 08 05	F6 03 04 09 06
.....

Notice:

1. When setting the code, learn the code first.
2. When connecting to RS232 or RS485, if the device cannot be controlled to perform related actions, please swap the two control lines.
3. The resistance of the wiring loop is less than 20Ω
4. Do not line up in parallel with strong interference sources

Control Interface

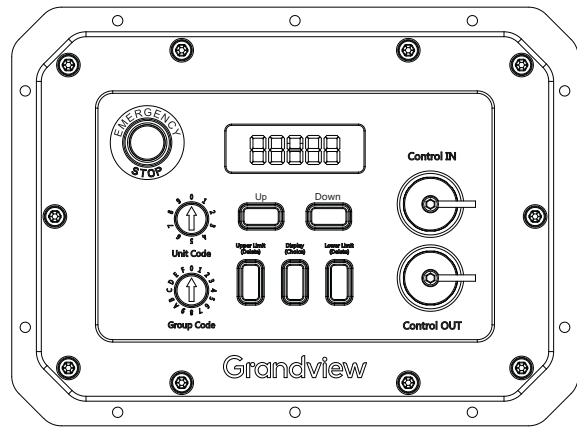

(GCRT-2512)



Emergency Stop Button
 Button down -the equipment is in debugging and normal use
 Button Release -the device is in a prohibited state



Up
 UP (Long Press)



Down
 Down (Long Press)



Upper Limit setting Button:
 Long press 3 second, you will hear 3 ticking from the hoist, then start setup upper limit. Press up and down button to setup the height you want. When in the height of target, press 4-5 second, you will hear 4 ticking from the hoist, then upper limit done.



Blank Button



Lower limit setting Button:
 Long press 3 second, you will hear 3 ticking from the hoist, then start setup lower limit. Press up and down button to setup the height you want. When in the height of target, press 4-5 second, you will hear 4 ticking from the hoist, then lower limit done.



Blank Button

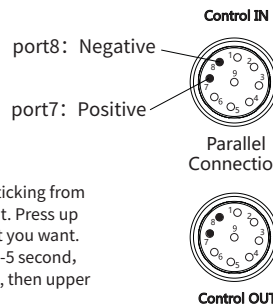

- 1- GND
- 2- DOWN
- 3-
- 4- UP
- 5-
- 6-
- 7- 485+
- 8- 485-
- 9-

Specification

GCRT-2512 :

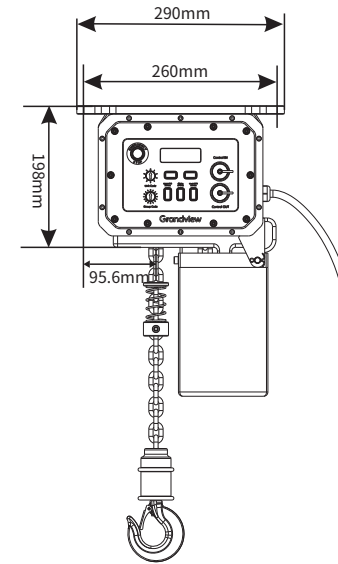

Front View

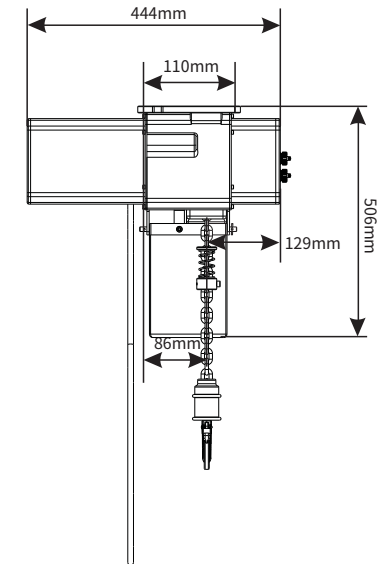

Side View

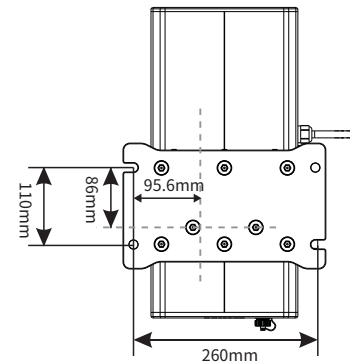

Top View

Specifications

Product: Electric Chain Hoist with Numerical Control
 Model: GCRT-2512
 Size: W444x D290 xH506mm
 Installation Bolt Hole Size: 260mm x110mm
 Ceiling open size: p175mm
 Loading capacity: 250 Kg
 Max dropping distance: 12 Meter
 Input Voltage: 220V/50Hz
 Power rating: 300W
 Control: RS-485/Dry Contact/Wall Switch

Installation instruction

Installation instruction

This product should be installed in the best projection position, it would be more convenient and more safe when the product being installed correctly, firstly, open the package and check if there is any missing parts, then take out all the parts and start the installation as per the instructions below, to make sure the product operates more safe and more convenient, pls read through the whole instruction carefully and choose the appropriate installation way based on the actual installation environment;

- *Power for rigging system is 300W, for cable manager is 60W, pls notice this when connecting the cables.
- *Installation can be arranged in the end of decoration, the decorative light circle of the bag can well cover the hole of smallpox, keep the appearance clean, and do not need a second decoration after installation.
- *After use, loosen the adjustable mechanical upper limit block screw to the minimum before recycling the chain.

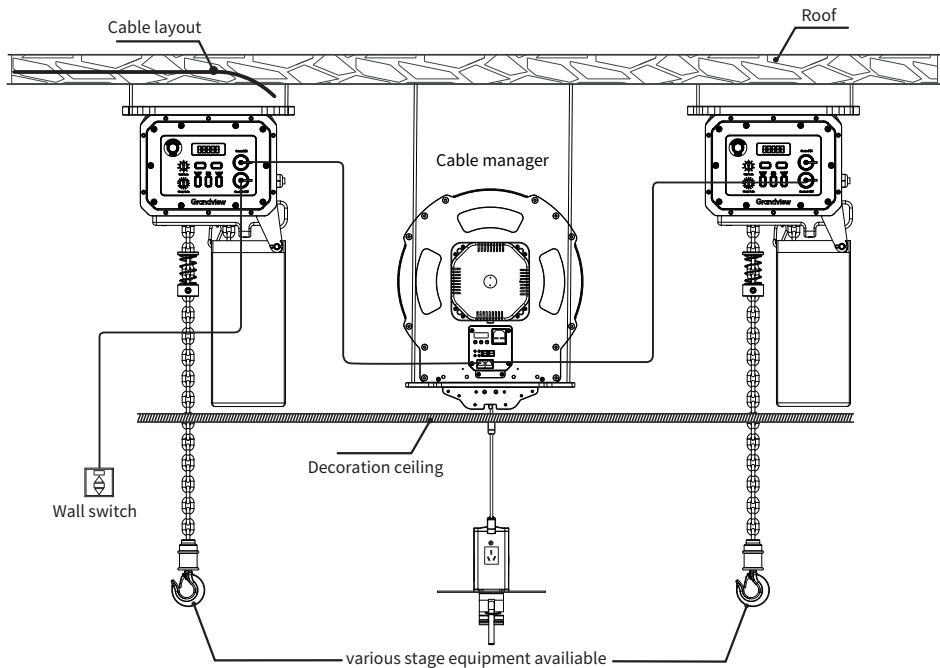

Recessed ceiling motorized lifts installation Diagram, pls notice that GSPC 12 is not a bearing products;

Notice:

- 1.End user can choose any port to connect the wall switch or central control;
- 2.hangers must keep straight;
- 3.When returning the chain, pls make sure all the stage equipments have been disassembled to avoid it hit the ceiling;

Installation effect

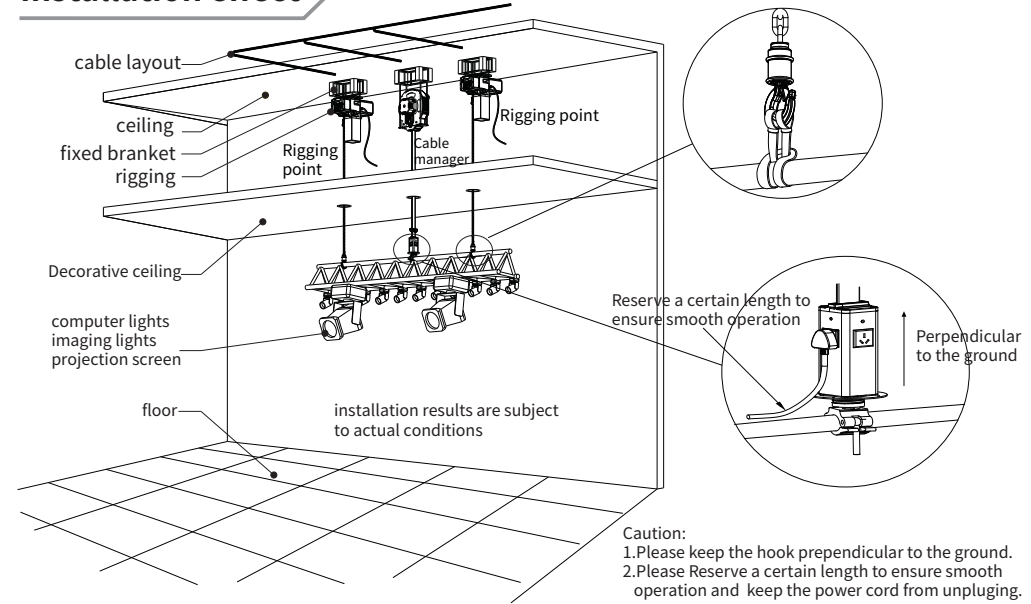

Installation instruction

- 1.Confirm the product installation position, install the steel structure into the concrete base, use screws to stabilize the steel structure;

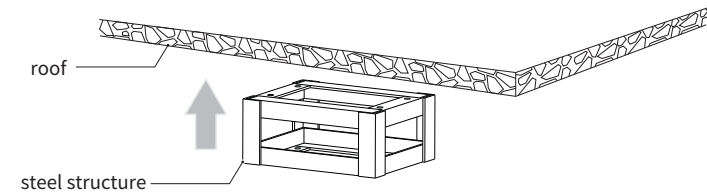

- 2.Use screws or rods to match the holes on the steel structure and tight it on the product;

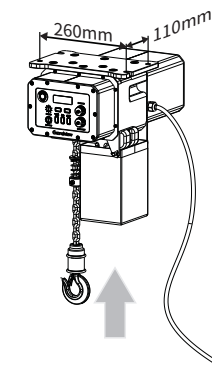

- 3.Opening hole on the ceiling, hole dimensions: 175mm;

